

||| HENNIG®

PROTECT YOUR SUCCESS

TRUCKPROTECT

Aluminum roll-up doors for fire and emergency trucks, work trucks, service trucks, utility vehicles and delivery vehicles



TRUCKPROTECT | FEATURES & COMPONENTS

Hennig's **TruckProtect** roll up door represents the latest and most innovative features available on vehicle roll-up doors today. With extensive worldwide experience in providing roll up products in the machinery industry, Hennig is now expanding into the work truck, service truck, utility vehicle, and delivery truck markets.

Aluminum roll-up doors not only avoid dangerous situations, they also offer a more compact, safer and durable solution than standard hinge doors.

- Safer than hinge doors which can swing out into traffic
- Design and precise tolerances provide the tightest sealing door on the market
- Slat interlocks and seal designs that promote no metal-to-metal contact, creating a much longer lifespan
- Low profile seal with low friction surface provides a tight seal and easy opening and closing
- "Bulb-style" bottom seal that less susceptible to damage
- Cycle tested for longevity
- Modular aluminum profiles for quick and easy repairs
- New space-saving design option available without a spring loaded roller

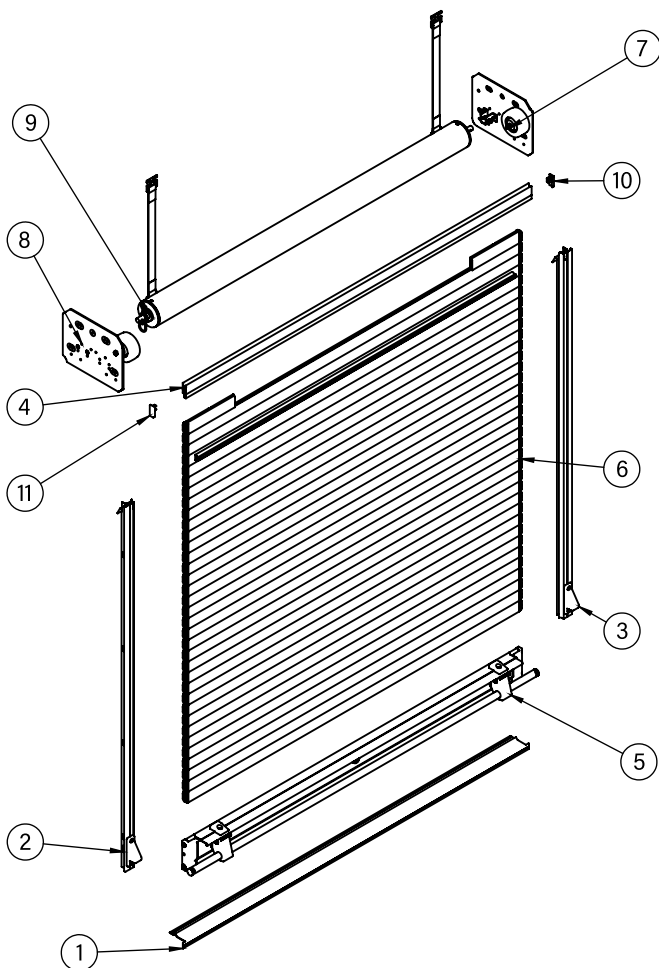

Item #	Description	Qty
1	sill plate profile	1
2	side rail assembly, left hand	1
3	side rail assembly, right hand	1
4	drip rail assembly	1
5	bottom rail assembly	1
6	apron assembly	1
7	pennant plate assembly, right hand	1
8	pennant plate assembly, left hand	1
9	roll up tube assembly	1
10	drip rail end cap, right hand	1
11	drip rail end cap, left hand	1

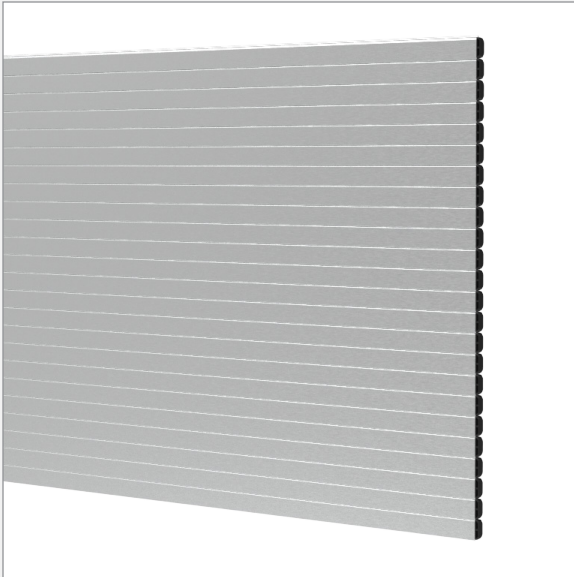

Aluminum slats

Lightweight, corrosion-resistant anodized



Double wall construction

Tight-tolerance interlocking joints with seals prevent water and dirt from entering the compartment.

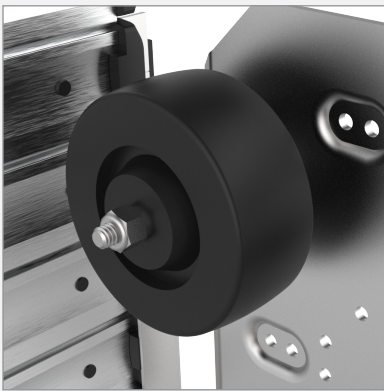

Rubber idler wheel

Provides quiet operation



Lift bar

Rigid, stainless steel makes for easy opening.

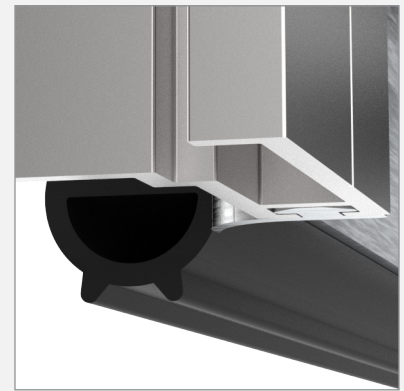

Bottom-bulb seal

Eliminates distortion and provides a tighter seal.



Side rail

With low profile, low friction seal.

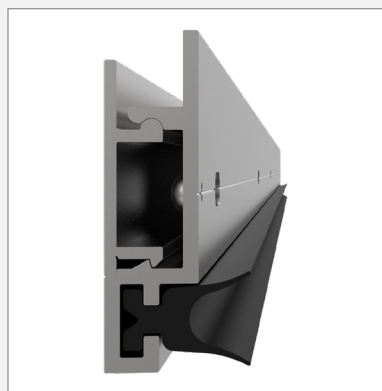

Top rail

With gutter and seal.



Bottom sill plate

With water dam.

Door Opening Height	Minimum Compartment Depth	Header Height	Maximum Roll-Up Diameter	Door Opening Width	Maximum Internal Height
up to 25	10.000	2.500	5.375	18	30
25 - 35	10.500	2.500	6.000	19	40
36 - 50	11.500	3.250	7.250	20	56
51 - 60	11.875	3.875	7.750	21	60
61 - 70	12.375	4.250	8.250	22 - 27	90
71 - 90	13.500	5.375	9.375	28 - 32	100
91 - 104	14.125	6.500	10.500	33 - 78	110

All measurements shown in inches (")

*Minimum header height is 2.50". Header heights shown can be used to better hide the rolled up door but are not necessarily required.

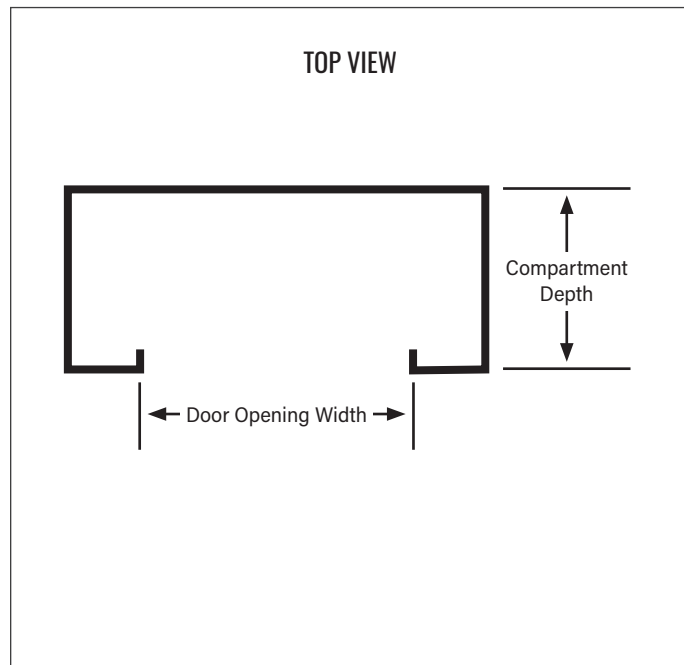
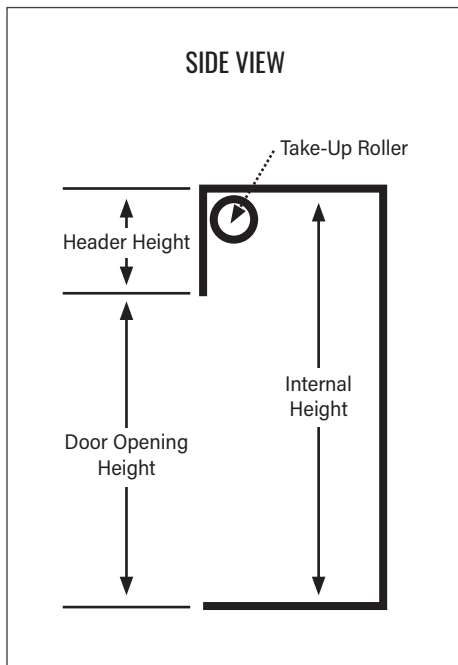

In the case of both hinged and roll-up doors, it can be difficult to find a manufacturer dedicated to long-term service and support. If you find a roll-up door expert, they can be your best option for maintenance and repairs as needed. For our TruckProtect series, our family-owned business with more than 65 of experience with machine protection (including roll-up doors, enclosures, bellows, and more) offers customers a quick and responsive service team.

CONTACT US

Brock Shattuck
 brock@hennig.ame.com
 815-316-5129

Ken Czyzewski
 ken.czyzewski@gmail.com
 262-853-0978

TAP Industrial Sales
 office@tapindsales.com
 877-827-4635